

Farbkombination - Tera

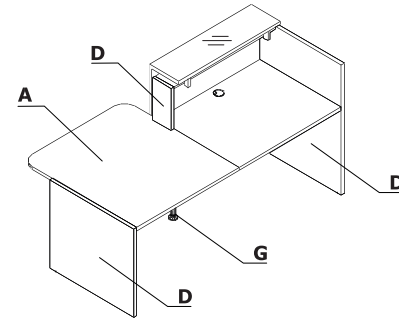
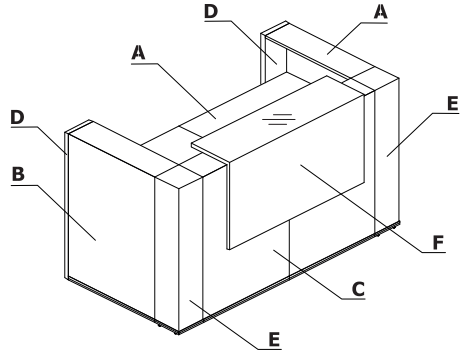

Material	Farbe	Alle Elemente													
		A - Oberplatte, Arbeitsplatte	B - Korpus	C - Front	D - Endelemente	E - Würfelfuß	F - Ansatz	G - Stützfuß							
Melamin	31 - kanadische Eiche	✓	✓	✓	✓										
	67 - weiß Pastell	✓	✓	✓	✓										
	106 - Nussbaum	✓	✓	✓	✓										
HPL	73 - weiß Glanz					✓	✓								
	101 - schwarz Glanz					✓	✓								
	155 - anthrazit Glanz					✓	✓								
	Metal - M015 - weiß halbmatt							✓							

## Technische Beschreibung

- 1 Arbeitsplatte** - Melaminplatte 28 mm, Umleimer ABS
- 2 Niedrige Seite** - Melaminplatte 28 mm, Umleimer ABS
- 3 Ansatz** - Oberplatte Melaminplatte 28 mm + Glas LACOBEL 4 mm, Front Melaminplatte 18 mm, beschichtet mit HPL Hochglanz
- 4 Hohe Seite** - Melaminplatte 28 mm, Umleimer ABS
- 5 Front** - Melaminplatte 18 mm, Umleimer ABS
- 6 Dekorstreifen** - PVC, M009 - aluminium halbmatt
- 7 Würfelfuß** - Melaminplatte, mit HPL Hochglanz beschichtet
- 8 Seite Verbindung der niedrigen und hohen Theken** - Melaminplatte 28 mm, Umleimer ABS
- 9 Stellage** - Metall, pulverbeschichtet, Weiß
- 10 Beleuchtungsschalter**
- 11 LED** - Beleuchtung - auf der ganzen Thekenlänge, Farbe Weiß, kalter Farbton (Weiß spielt leicht ins Blau);
- 12 Kabeldurchlässe** - Ø80 mm
- 13 Stützfuß NL41** - aus Metall, bei Verbindung der Platten notwendig

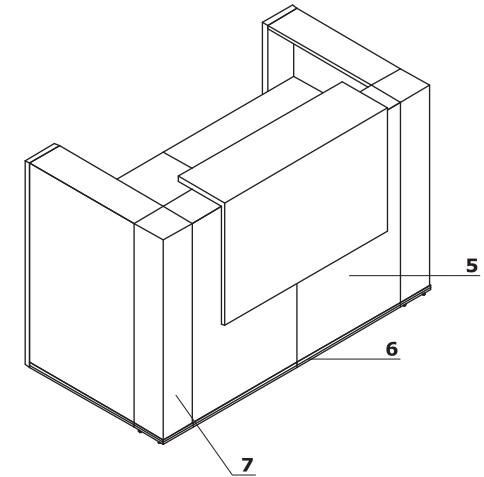
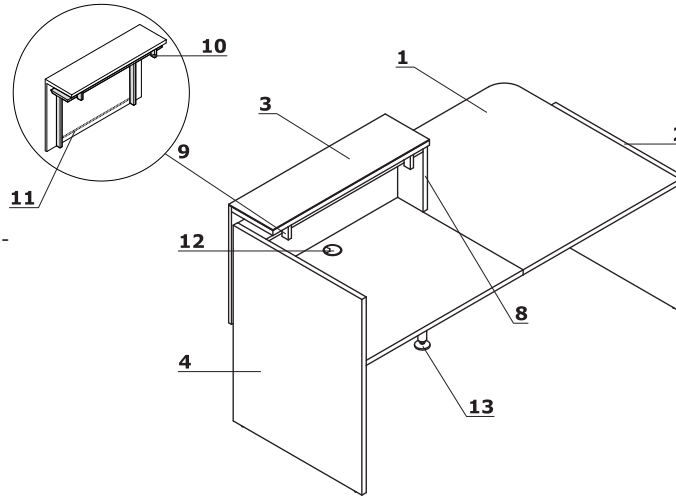

## Verwendung von endelementen

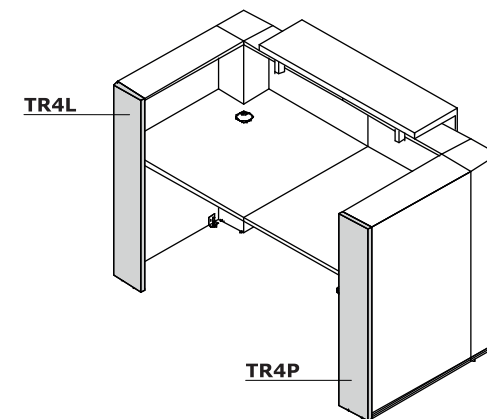
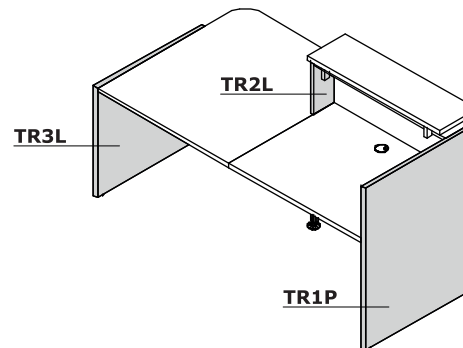
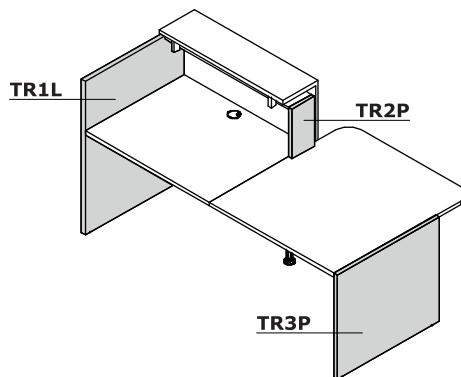

Abmessungen (mm)

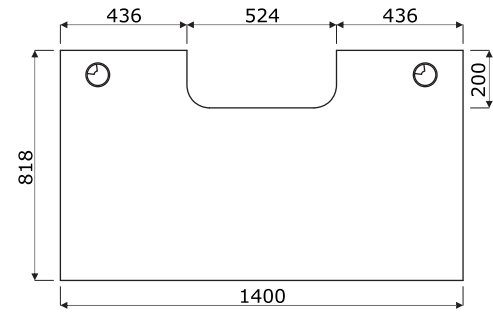
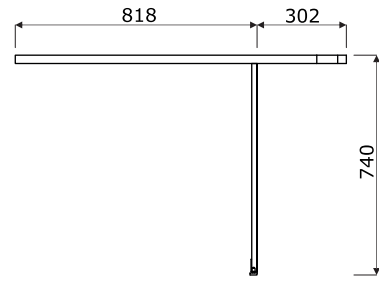
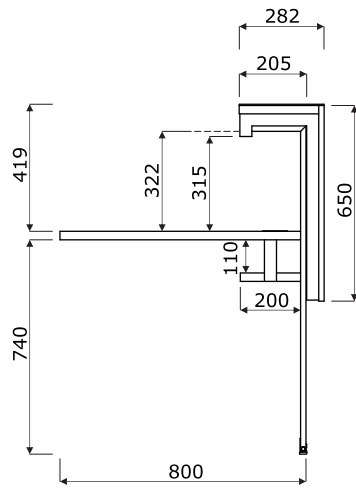

Symbol		Abmessungen					kg m3 pcs	Bestandteile
		W1	W2	D1	D2	H		
<b>TRA13</b>		856	820	2608	838	1090	59 kg 0.124 m3 3 pcs	TR1L+TR08+TR1P

Aufpreis						

Symbol		Abmessungen					kg m3 pcs	Bestandteile
		W1	W2	D1	D2	H		
<b>TRA14</b>		1056	877	2608	838	1159	83 kg 0.32 m3 4 pcs	TR1L+TR10+TR99+TR1P
<b>TRA15</b>		1256	877	2608	838	1159	87 kg 0.332 m3 4 pcs	TR1L+TR12+TR99+TR1P
<b>TRA16</b>		1456	877	2608	838	1159	89 kg 0.344 m3 4 pcs	TR1L+TR14+TR99+TR1P

Aufpreis						
Monitorboden x 1p						
	X					
	X					
	X					

Symbol		Abmessungen					kg m3 pcs	Bestandteile
		W1	W2	D1	D2	H		
<b>TRA17</b>		1656	877	2608	838	1159	103 kg 0.425 m3 6 pcs	TR1L+2xTR08+TR99+TR1P+NL41
<b>TRA18</b>		2056	877	2608	838	1159	117 kg 0.449 m3 6 pcs	TR1L+2xTR10+TR99+TR1P+NL41
<b>TRA19</b>		2456	877	2608	838	1159	125 kg 0.473 m3 6 pcs	TR1L+2xTR12+TR99+TR1P+NL41
<b>TRA20</b>		2856	877	2608	838	1159	129 kg 0.498 m3 6 pcs	TR1L+2xTR14+TR99+TR1P+NL41

Aufpreis						
Monitorboden x 1p	Monitorboden x 2					
X	X					
X	X					
X	X					

Symbol		Abmessungen					kg m3 pcs	Bestandteile
		W1	W2	D1	D2	H		
<b>TRA117</b>		1656	820	2608	838	1090	86 kg 0.242 m3 5 pcs	TR1L+2xTR08+TR1P+NL41
<b>TRA118</b>		2056	820	2608	838	1090	100 kg 0.266 m3 5 pcs	TR1L+2xTR10+TR1P+NL41
<b>TRA119</b>		2456	820	2608	838	1090	108 kg 0.29 m3 5 pcs	TR1L+2xTR12+TR1P+NL41
<b>TRA120</b>		2856	820	2608	838	1090	112 kg 0.314 m3 5 pcs	TR1L+2xTR14+TR1P+NL41

Aufpreis						
Monitorboden x 1p	Monitorboden x 2					
X	X					
X	X					
X	X					

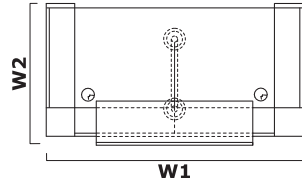
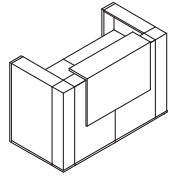

Symbol		Abmessungen					kg m3 pcs	Bestandteile
		W1	W2	D1	D2	H		
<b>TRA42</b>		1640	905	2608	838	1159	99 kg 0.46 m3 8 pcs	TR4L+2xTR90+TR4P+TR99+NL41

Aufpreis						

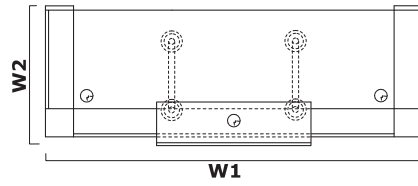
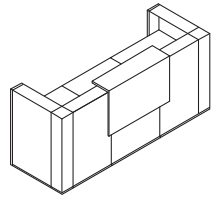

Symbol		Abmessungen					kg m3 pcs	Bestandteile
		W1	W2	D1	D2	H		
<b>TRA21</b>		2440	905	2608	838	1159	126 kg 0.577 m3 10 pcs	TR4L+2xTR90+TR08+TR4P+TR99+2xNL41
<b>TRA22</b>		2640	905	2608	838	1159	133 kg 0.59 m3 10 pcs	TR4L+2xTR90+TR10+TR4P+TR99+2xNL41
<b>TRA23</b>		2840	905	2608	838	1159	137 kg 0.602 m3 10 pcs	TR4L+2xTR90+TR12+TR4P+TR99+2xNL41
<b>TRA24</b>		3040	905	2608	838	1159	139 kg 0.614 m3 10 pcs	TR4L+2xTR90+TR14+TR4P+TR99+2xNL41

Aufpreis						
Monitorboden x 1p						
X						
X						
X						

Symbol		Abmessungen					kg m3 pcs	Bestandteile
		W1	W2	D1	D2	H		
<b>TRA121</b>		2440	848	2608	838	1090	109 kg 0.394 m3 9 pcs	TR4L+2xTR90+TR08+TR4P +2xNL41
<b>TRA122</b>		2640	848	2608	838	1090	116 kg 0.406 m3 9 pcs	TR4L+2xTR90+TR10+TR4P +2xNL41
<b>TRA123</b>		2840	848	2608	838	1090	120 kg 0.418 m3 9 pcs	TR4L+2xTR90+TR12+TR4P +2xNL41
<b>TRA124</b>		3040	848	2608	838	1090	122 kg 0.43 m3 9 pcs	TR4L+2xTR90+TR14+TR4P +2xNL41

Aufpreis						
Monitorboden x 1p						
X						
X						
X						

Symbol		Abmessungen					kg m3 pcs	Bestandteile
		W1	W2	D1	D2	H		
<b>TRA25</b>		1648	1705	2608	838	1159	141 kg 0.586 m3 9 pcs	TR1L+TR08+TR90+TR08+TR1P +TR99+2xNL41
<b>TRA26</b>		1848	1705	2608	838	1159	148 kg 0.598 m3 9 pcs	TR1L+TR08+TR90+TR10+TR1P +TR99+2xNL41
<b>TRA27</b>		2048	1705	2608	838	1159	152 kg 0.611 m3 9 pcs	TR1L+TR08+TR90+TR12+TR1P +TR99+2xNL41
<b>TRA28</b>		2248	1705	2608	838	1159	154 kg 0.623 m3 9 pcs	TR1L+TR08+TR90+TR14+TR1P +TR99+2xNL41

Aufpreis						
Monitorboden x 1p						
X						
X						
X						

Symbol		Abmessungen					kg m3 pcs	Bestandteile
		W1	W2	D1	D2	H		
<b>TRA29</b>		3240	1705	2608	838	1159	250 kg 1.166 m3 17 pcs	TR1L+2xTR08+2xTR90+2xTR08 +TR1P+2xTR99+5xNL41
<b>TRA30</b>		3640	1705	2608	838	1159	264 kg 1.19 m3 17 pcs	TR1L+2xTR08+2xTR90+2xTR10+TR1P+2xTR99+5xNL41
<b>TRA31</b>		4040	1705	2608	838	1159	272 kg 1.214 m3 17 pcs	TR1L+2xTR08+2xTR90+2xTR12+TR1P+2xTR99+5xNL41
<b>TRA32</b>		4440	1705	2608	838	1159	276 kg 1.239 m3 17 pcs	TR1L+2xTR08+2xTR90+2xTR14 +TR1P+2xTR99+5xNL41

Aufpreis					
Monitorboden x 1p	Monitorboden x 2				
X	X				
X	X				
X	X				

Symbol		Abmessungen					kg m3 pcs	Bestandteile
		W1	W2	D1	D2	H		
<b>TRA129</b>		3354	1705	2608	838	1159	267 kg 1.349 m3 18 pcs	TR1L+2xTR08+2xTR90+2xTR08 +TR1P+3xTR99+5xNL41
<b>TRA130</b>		3754	1705	2608	838	1159	281 kg 1.374 m3 18 pcs	TR1L+2xTR08+2xTR90+2xTR10 +TR1P+3xTR99+5xNL41
<b>TRA131</b>		4154	1705	2608	838	1159	289 kg 1.398 m3 18 pcs	TR1L+2xTR08+2xTR90+2xTR12 +TR1P+3xTR99+5xNL41
<b>TRA132</b>		4554	1705	2608	838	1159	293 kg 1.422 m3 18 pcs	TR1L+2xTR08+2xTR90+2xTR14 +TR1P+3xTR99+5xNL41

Aufpreis					
Monitorboden x 1p	Monitorboden x 2				
X	X				
X	X				
X	X				



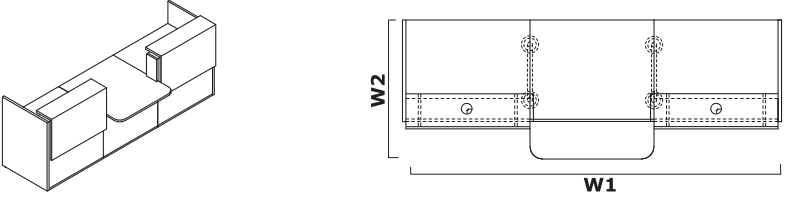

Symbol		Abmessungen					kg m3 pcs	Bestandteile
		W1	W2	D1	D2	H		
<b>TRA33</b>		3056	1120	2608	838	1159	169 kg 0.793 m3 11 pcs	TR1L+TR10+TR2P+TR11+TR2L +TR10+TR1P+2xTR99+2xNL41
<b>TRA34</b>		3456	1120	2608	838	1159	177 kg 0.817 m3 11 pcs	TR1L+TR12+TR2P+TR11+TR2L +TR12+TR1P+2xTR99+2xNL41
<b>TRA35</b>		3856	1120	2608	838	1159	181 kg 0.841 m3 11 pcs	TR1L+TR14+TR2P+TR11+TR2L +TR14+TR1P+2xTR99+2xNL41

Aufpreis						
Monitorboden x 1p	Monitorboden x 2					
X	X					
X	X					
X	X					

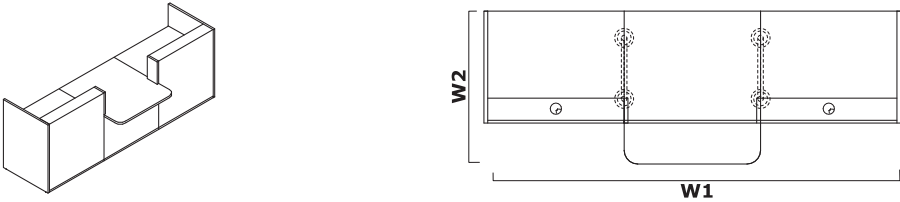

Symbol		Abmessungen					kg m3 pcs	Bestandteile
		W1	W2	D1	D2	H		
<b>TRA133</b>		3056	1120	2608	838	1090	135 kg 0.426 m3 9 pcs	TR12+TR10+TR2P+TR11+TR2L +TR10+TR1P+2xNL41
<b>TRA134</b>		3456	1120	2608	838	1090	143 kg 0.451 m3 9 pcs	TR12+TR12+TR2P+TR11+TR2L +TR12+TR1P+2xNL41
<b>TRA135</b>		3856	1120	2608	838	1090	147 kg 0.475 m3 9 pcs	TR12+TR14+TR2P+TR11+TR2L +TR14+TR1P+2xNL41

Aufpreis						
Monitorboden x 1p	Monitorboden x 2					
X	X					
X	X					
X	X					

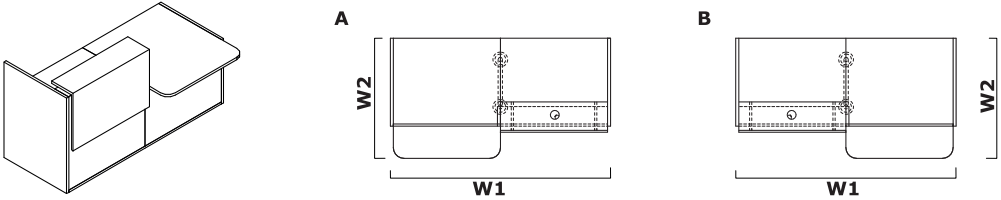

Symbol		Abmessungen	kg m3 pcs	Bestandteile
A	B			
<b>TRA36L</b>	<b>TRA36P</b>	W1: 2056, W2: 1120, D1: 2608, D2: 838, H: 1159	111.5 kg 0.467 m3 7 pcs	A - TR1L+TR10+TR2P+TR11+TR3P +TR99+NL41 B - TR3L+TR11+TR2L+TR10+TR1P +TR99+NL41
<b>TRA37L</b>	<b>TRA37P</b>	W1: 2256, W2: 1120, D1: 2608, D2: 838, H: 1159	115.5 kg 0.479 m3 7 pcs	A - TR1L+TR12+TR2P+TR11+TR3P +TR99+NL41 B - TR3L+TR11+TR2L+TR12+TR1P +TR99+NL41
<b>TRA38L</b>	<b>TRA38P</b>	W1: 2456, W2: 1120, D1: 2608, D2: 838, H: 1159	158.5 kg 0.587 m3 9 pcs	A - TR1L+TR14+TR2P+TR11+TR3P +TR99+NL41 B - TR3L+TR11+TR2L+TR14+TR1P +TR99+NL41

Aufpreis					
Monitorboden x 1p					
X					
X					
X					

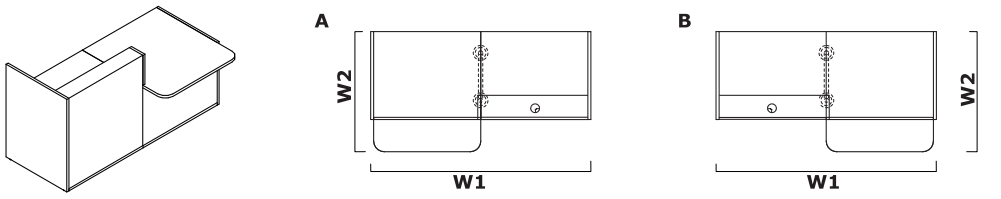

Symbol		Abmessungen	kg m3 pcs	Bestandteile
A	B			
<b>TRA136L</b>	<b>TRA136P</b>	W1: 2056, W2: 1120, D1: 2608, D2: 838, H: 1090	94.5 kg 0.283 m3 6 pcs	A - TR1L+TR10+TR2P+TR11+TR3P +NL41 B - TR3L+TR11+TR2L+TR10+TR1P +NL41
<b>TRA137L</b>	<b>TRA137P</b>	W1: 2256, W2: 1120, D1: 2608, D2: 838, H: 1090	98.5 kg 0.295 m3 6 pcs	A - TR1L+TR12+TR2P+TR11+TR3P +NL41 B - TR3L+TR11+TR2L+TR12+TR1P +NL41
<b>TRA138L</b>	<b>TRA138P</b>	W1: 2456, W2: 1120, D1: 2608, D2: 838, H: 1090	100.5 kg 0.308 m3 6 pcs	A - TR1L+TR14+TR2P+TR11+TR3P +NL41 B - TR3L+TR11+TR2L+TR14+TR1P +NL41

Aufpreis					
Monitorboden x 1p					
X					
X					
X					

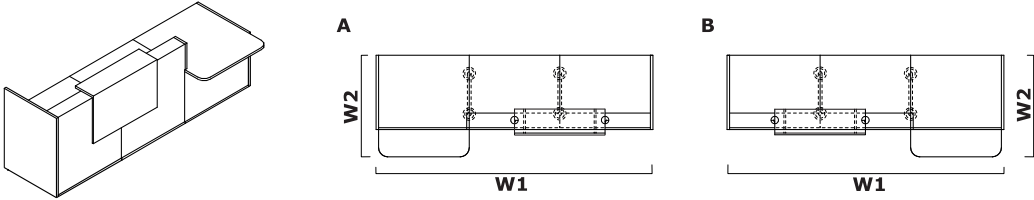

Symbol			Abmessungen					kg m3 pcs	Bestandteile
A	B		W1	W2	D1	D2	H		
<b>TRA39L</b>	<b>TRA39P</b>		3056	1120	2608	838	1159	145.5 kg 0.596 m3 9 pcs	A - TR1L+2xTR10+TR2P+TR11+TR3P+TR99+2xNL41 B - TR3L+TR11+TR2L+2xTR10+TR1P+TR99+2xNL41
<b>TRA40L</b>	<b>TRA40P</b>		3456	1120	2608	838	1159	153.5 kg 0.62 m3 9 pcs	A - TR1L+2xTR12+TR2P+TR11+TR3P+TR99+2xNL41 B - TR3L+TR11+TR2L+2xTR12+TR1P+TR99+2xNL41
<b>TRA41L</b>	<b>TRA41P</b>		3856	1120	2608	838	1159	157.5 kg 0.645 m3 9 pcs	A - TR1L+2xTR14+TR2P+TR11+TR3P+TR99+2xNL41 B - TR3L+TR11+TR2L+2xTR14+TR1P+TR99+2xNL41

Aufpreis						
Monitorboden x 1p	Monitorboden x 2					
X	X					
X	X					
X	X					



